

A low power multichannel analog front end for portable neural signal recordings

Iyad Obeid^{a,*}, Miguel A.L. Nicolelis^{a,b,c,d}, Patrick D. Wolf^a

^a Department of Biomedical Engineering, Duke University, Durham, NC 27708, USA

^b Department of Neurobiology, Duke University, Durham, NC 27708, USA

^c Department of Psychological and Brain Sciences, Duke University, Durham, NC 27708, USA

^d Co-director-Duke Center for Neuroengineering, Duke University, Durham, NC 27708, USA

Received 21 February 2003; received in revised form 9 June 2003; accepted 12 September 2003

Abstract

We present the design and testing of a 16-channel analog amplifier for processing neural signals. Each channel has the following features: (1) variable gain (70–94 dB), (2) four high pass Bessel filter poles ($f_{-3\text{dB}} = 445\text{ Hz}$), (3) five low pass Bessel filter poles ($f_{-3\text{dB}} = 6.6\text{ kHz}$), and (4) differential amplification with a user selectable reference channel to reject common mode background biological noise. Processed signals are time division multiplexed and sampled by an on-board 12-bit analog to digital converter at up to 62.5k samples/s per channel. The board is powered by two low dropout voltage regulators which may be supplied by a single battery. The board measures 8.1 cm × 9.9 cm, weighs 50 g, and consumes up to 130 mW. Its low input-referred noise ($1.0\ \mu\text{V}_{\text{RMS}}$) makes it possible to process low amplitude neural signals; the board was successfully tested in vivo to process cortically derived extracellular action potentials in primates. Signals processed by this board were compared to those generated by a commercially available system and were found to be nearly identical. Background noise generated by mastication was substantially attenuated by the selectable reference circuit. The described circuit is light weight and low power and is used as a component of a wearable multichannel neural telemetry system.

© 2003 Elsevier B.V. All rights reserved.

Keywords: Single unit recording; Neural signal processing; Low-power

1. Introduction

Multichannel neural recordings are used to study the behavior of populations of neurons in various parts of the brain (Hampson et al., 1999; Katz et al., 2002; Ohl et al., 2001; Wessberg et al., 2000). However, the requirement of a cable tether for acquiring data necessitates physical restraint of the subject. In order to study populations of neurons in freely moving subjects, we require a wearable multichannel neural telemetry system. This work presents the design and testing of a low-power 16-channel analog front end (AFE) for use in such a system. The AFE amplifies, filters, and digitizes neural signals, and has been tested in primates. All components are available off the shelf, and all production files for the required printed circuit boards have been made available online, thus making the circuit easily reproducible.

2. System design

The AFE is comprised of 16 parallel channels, each with four identical analog processing stages: preamplifier, differential amplifier, filter, and variable gain (Fig. 1). Two 8:1 multiplexers and three SPST switches provide reference selection for the differential amplifiers. A 16:1 time division multiplexer (TDM) selects channels to be sampled by the analog to digital converter (ADC). The gain is designed to vary between 3200 (70 dB) and 50,000 (94 dB), and the bandpass filter corner frequencies are placed at 350 and 8 kHz. The front end is designed to be driven by an active headstage. The schematic for a single channel is shown in Fig. 2.

2.1. Analog block

2.1.1. Preamplifier

The preamplifier is comprised of the unity gain high-pass filter formed by C_1 and R_1 , and the non-inverting low-pass

* Corresponding author. Tel.: +1-919-660-5109;

fax: +1-919-660-5405.

E-mail address: io@duke.edu (I. Obeid).

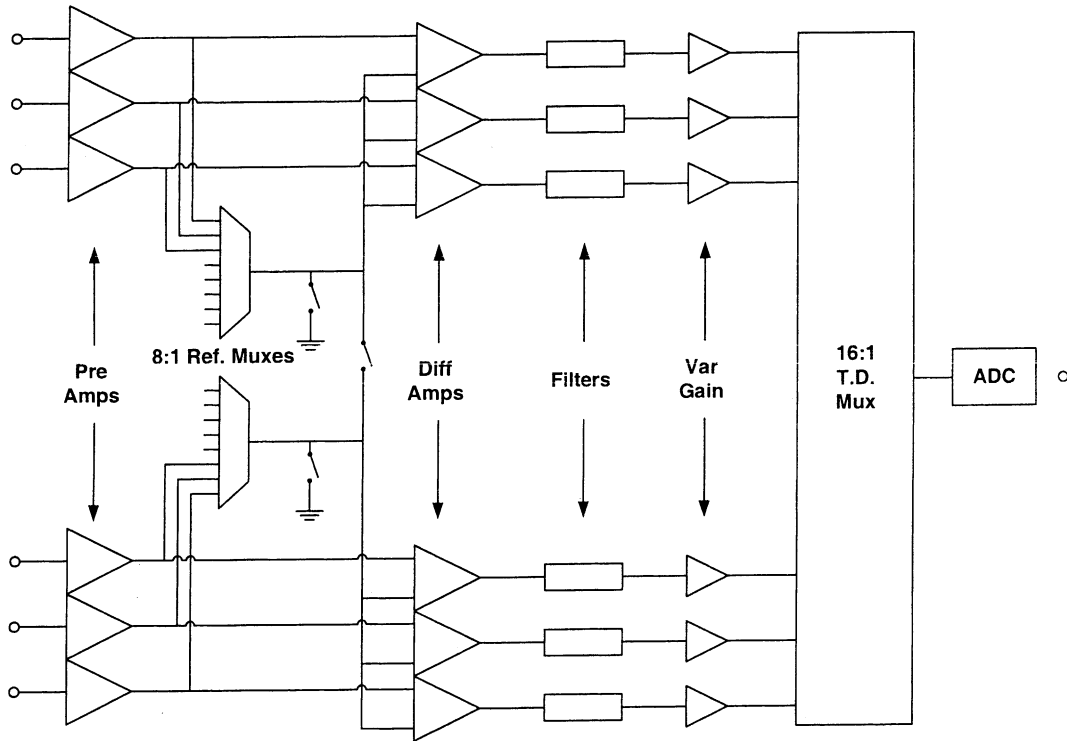

Fig. 1. The overall block diagram of the 16-channel analog front end. Electrode signals are input at the left. Referencing for the differential amplifiers is handled by a pair of 8:1 multiplexers and three switches. The user can therefore select either a bipolar (referenced to another channel) or unipolar (referenced to ground) reference for each of the two 8-channel groups. One channel can also be selected as the bipolar reference for the whole board. The variable gain for each channel is determined by a user controlled digital potentiometer. Processed signals are time-division multiplexed and sampled. The digitized data stream must be processed off-board.

filter with gain formed by Amp1, R_2 , R_3 , and C_2 . The Maxim 4253 (Maxim IC, Sunnyvale, CA) op-amp used for Amp1 features low noise density ($7.9 \text{ nV}/\sqrt{\text{Hz}}$), and may be shutdown to reduce power consumption when its channel is not in use. The preamplifier gain is fixed at 100.

2.1.2. Differential amplifier

The differential amplifier stage combines a gain of 10 with a high-pass filter pole. Amp2 (Maxim 4199) provides the differential gain with a common mode rejection ratio (CMRR) of $\sim 110 \text{ dB}$, while the integrator in the feedback

pathway adds the pole. Note that the differential amplifier's V_{ref} input is taken from one of the two 8:1 reference multiplexers (Fig. 1). The 4199 may be shut down when not in use, and the feedback op-amp (OPA2244, Burr Brown/Texas Instruments, Dallas, TX) consumes only $50 \mu\text{A}$.

2.1.3. Reference selection

A reference selection circuit allows the user to specify the differential amplifiers' reference signals. The AFE's 16-channels are divided into two groups of eight. The preamplifier outputs for each group are wired into an 8:1 multi-

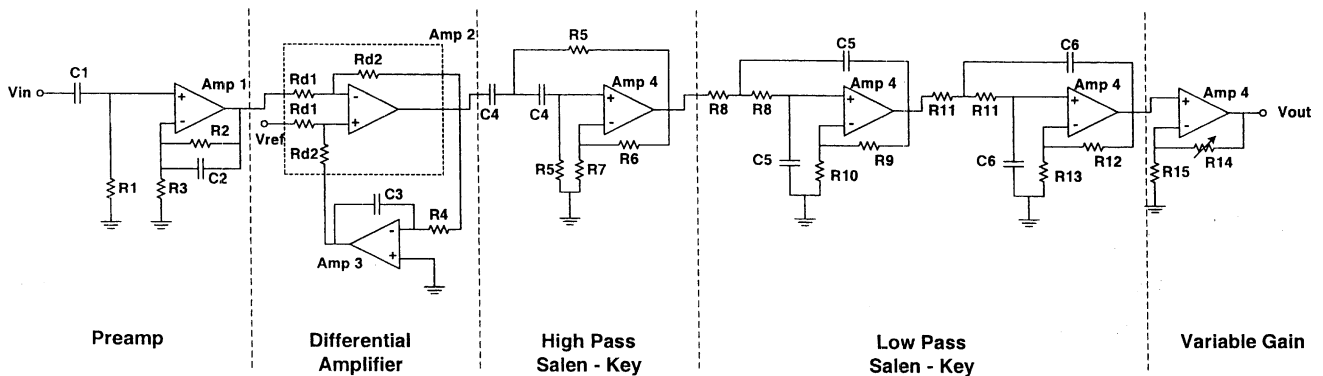

Fig. 2. Schematic for a full analog front end channel. The V_{in} input is taken from a headstage buffered electrode, and the V_{ref} input is taken from the output of the channel's respective 8:1 multiplexer. V_{out} connects to the 16:1 time division multiplexer. All components are available off-the-shelf.

plexer, allowing one of those channels to be chosen as the reference from that eight-channel group (Fig. 1). Additionally, three switches operated in tandem with the 8:1 multiplexers allow for a single signal to be the reference for all 16 channels, or for a separate ground electrode to be the reference. The Analog Devices AD708 (Analog Devices, Norwood, MA) was selected for the two 8:1 multiplexers, and the Maxim 4626 was chosen for the SPST switches.

2.1.4. Filters

The filter stage is comprised of three Sallen-Key filters—one high-pass cascaded into two low-pass filters. We used these filters, in combination with those in the preamplifier and differential amplifier stages, to form Bessel filters. The Sallen-Key filter op-amp is the quad package Microchip MCP604.

2.1.5. Variable gain

The variable gain stage increases the system's dynamic range, reducing the number of bits of resolution required in the analog to digital converter. The variable gain, controlled by a 200 k Ω 32-tap digital potentiometer (Maxim 5160), is evenly spaced between 1 and 16.5. The op-amp is the fourth device on the MCP604 used for the Sallen-Key filters.

2.2. Digital block

The analog signals are time-division multiplexed using the Analog Devices AD706 and sampled with the Analog Devices AD7495. The AD7495 is a 12-bit low power (4.5 mW) successive approximation ADC with a maximum throughput rate of 1M samples/s, allowing each of the 16 channels to be sampled at up to 62.5k samples/s. Timing signals for the multiplexer and ADC must be generated off-board.

2.3. Power supply

Power for the board is supplied by two high precision, low dropout voltage regulators, Analog Devices REF191 and REF198, which generate 2.048 and 4.096 V, respectively. The 2.048 V rail is used as a virtual ground, effectively creating a ± 2.048 V power supply without requiring an inverting voltage regulator or negative power supply. Since the REF191 (acting as the virtual ground) is incapable of sinking current, its output is buffered with a unity gain source follower (Analog Devices OP262). This virtual ground is used to ground the subject. The circuit is designed to be powered by an isolated power source, ideally a battery.

2.4. Physical circuit

A six-layer 8.1 cm \times 9.9 cm printed circuit board (PCB) was designed for the 16 AFE channels, the reference selection circuits, and the power supply, as well as two 30-pin digital I/O connectors and a 26-pin analog input connector. The analog channels were laid out in eight parallel rows on

each side of the board. A high board density was achieved by using the smallest available hand-solderable parts (size 0402 for the passive components), 6.25 mil signal trace widths, and 24 mil vias with 10 mil drill holes. The analog input connector includes the 16 input lines plus two power and two ground lines for powering an active headstage. The preamplifier and differential amplifier stages were protected from electromagnetic radiation by a grounded metal shield placed over both sides of the board.

The AFE requires 50 digital control signals that must be generated off-board. Power supply lines for the two voltage regulators must also be generated off-board. The digitized data serial bitstream is the only signal output by the AFE board. Digital I/O is handled through two parallel 30-pin connectors (Advanced Interconnect, West Warwick, RI). These carry the 50 control signals, plus four voltage reference power supply lines, four ground lines, and the one digital data output. The connectors may be used to control the AFE board using either a remote computer (via cable) or a local digital board that plugs directly into the AFE. This board would house power supply circuitry and programmable logic to manage the AFE's digital I/O (Obeid et al., 2004).

3. Methods

The AFE board was manufactured using standard PCB technology. Schematics, circuit board Gerber files, and a complete bill of materials may be found at <http://dukebme.duke.edu/backpack>. The AFE was characterized using a high precision evaluation deck (System-Two, Audio Precision, Beaverton, OR), and tested in vivo on a macaque (*Macaca mulatta*). The subject had electrodes implanted in the somatosensory cortex near spontaneously firing neurons (Nicolelis et al., 1997). The electrodes were buffered with commercially available headstages (HST/8o50-G20-GR, Plexon Inc., Dallas, TX) and connected via a short cable (FlatFlex, Parlex Inc., Methuen, MA) to the AFE's input. Control signals for the AFE were provided from a custom designed digital board with programmable logic.

The board's in vivo performance was compared to that of a commercial neural data acquisition system (MNAP, Plexon Inc.). A "Y"-adapter was used to split the raw electrode signals. The first "Y" branch was buffered by a Plexon headstage, processed by the MNAP, and then saved using a digital tape deck (DA-38, TASCAM; 20 Hz–20 kHz, $F_s = 44.1$ kHz). The second branch was buffered with a custom headstage (Obeid et al., 2003), processed by our AFE ($F_s = 30$ kHz), and stored as eight-bit samples on a PC hard drive. The signals were compared by resampling the AFE signals at 44.1 kHz in MATLAB and then normalizing both signals.

The selectable reference channel feature was evaluated by recording signals during mastication. Signals were first recorded from two adjacent microwire electrodes (channels 1 and 2) referenced to a separate ground while the subject chewed continuously. Channel 1 was then referenced to

channel 2 and recorded during a similar period of continuous chewing. The recordings were analyzed for evidence of signal artifacts generated by the chewing.

4. Results

The AFE board measures $8.1 \text{ cm} \times 9.9 \text{ cm}$ and weighs 50 g, including all sockets, components, and the lightweight metal shielding. The AFE's performance is summarized in Table 1. Predicted values are based on SPICE simulations and component data sheets. Differences between the measured and predicted values of the gains and pole locations can be attributed entirely to capacitor and resistor tolerances. The CMRR value of 42.3 dB is the mean ($n = 15$) of the CMRR measurements made at 1 kHz between adjacent channels on the board. The measured input referred noise value corresponds to a noise density of $12.8 \text{ nV}/\sqrt{\text{Hz}}$. Noise measurements were made under normal laboratory conditions (i.e. normal ambient noise sources) without an active headstage. The maximum signal to noise plus distortion ratio (SNDR) ranged from 29.4 dB at the maximum gain to 52.4 dB at the minimum gain.

Fig. 3 shows a comparison of neural signals processed in parallel by the AFE and the Plexon MNAP; the signals are nearly identical. The average root mean square error between the AFE and MNAP signals is $5.2 \mu\text{V}_{\text{RMS}}$. This is attributable to (1) AFE circuit noise, (2) noise differences between the Plexon and custom headstages, (3) differences in filtering between the AFE, the MNAP, and the anti-aliasing filter of the digital tape recorder, and (4) the resampling required to compare the signals.

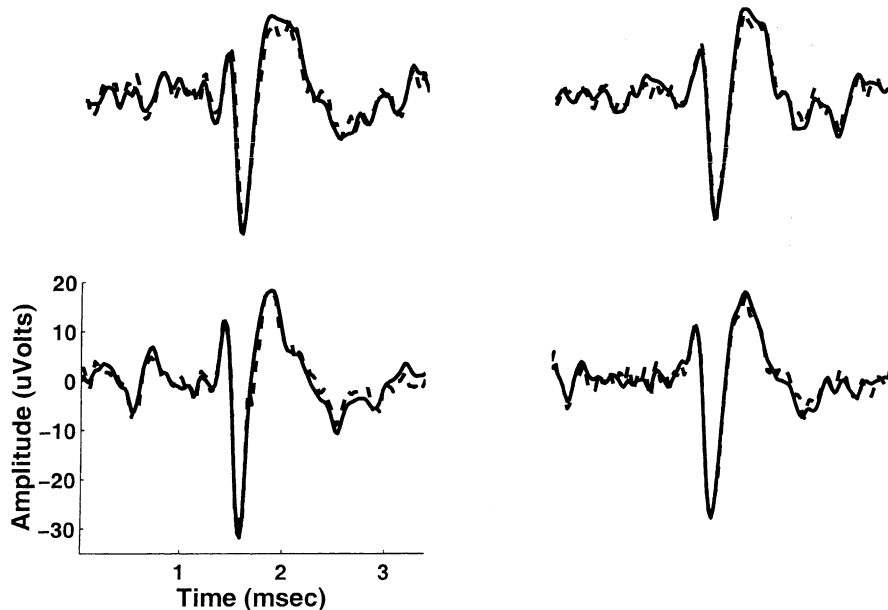

Fig. 3. Equivalence of the analog front end to a commercial recording system. Samples of primate signals recorded in parallel through our analog front end (dashed traces) and the Plexon MNAP system (solid traces). The signals are nearly identical. The mean root mean square error between the two sets of waveforms is $5.2 \mu\text{V}_{\text{RMS}}$.

Table 1
Summary of electrical characteristics

Parameter	Measured value	Predicted value
Gain (low)	$69.4 \pm 0.11 \text{ dB}$	70.0 dB
Gain (high)	$93.4 \pm 0.08 \text{ dB}$	94.4 dB
$f_{-3\text{dB}}$ (low)	$445 \pm 6.5 \text{ Hz}$	390 Hz
$f_{-3\text{dB}}$ (high)	$6.55 \pm 0.5 \text{ kHz}$	7.59 kHz
CMRR	42.3 dB	39.2 dB (worst case)
Group delay (maximum)	2.0 ms	3.8 ms
Noise (input referred)	$1.0 \mu\text{V}_{\text{RMS}}$	$0.7 \mu\text{V}_{\text{RMS}}$
Power consumption	130 mW	130 mW
Full scale input range	1.4 mV at minimum gain $87 \mu\text{V}$ at maximum gain	1.3 mV 78 μV
Common mode range	$\geq \pm 10.5 \text{ V}$	

The utility of the selectable reference electrode matrix is demonstrated in Fig. 4. The top two traces, recorded simultaneously from two adjacent electrodes during mastication, demonstrate that large signal artifacts are common to both electrodes. In the third trace, the reference selection circuit is used to make a bipolar recording between the electrodes of the first two traces. No signal artifacts are present.

5. Discussion

Our design will be useful for any research requiring a low power multichannel circuit for processing and digitizing extracellular neural signals. Aspects of this architecture such as the ground referencing scheme or the low noise/high gain preamplifiers may be adapted for related applications.

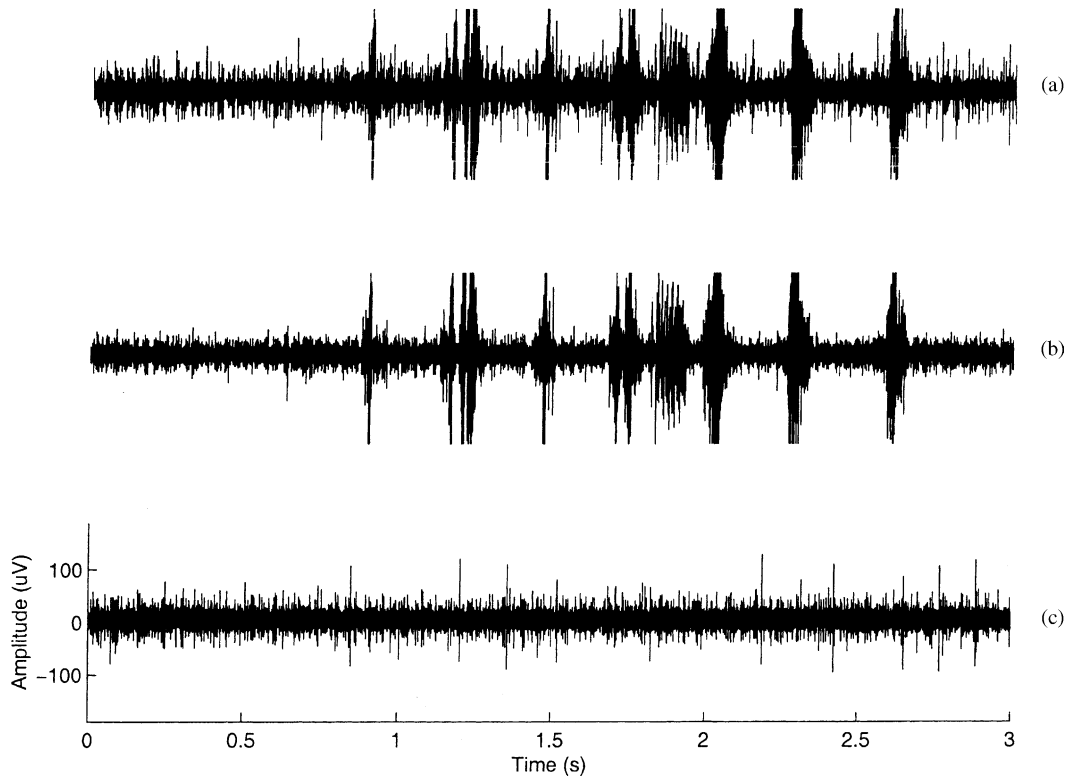

Fig. 4. Use of the reference channel selection feature to remove signal artifacts. Traces (a) and (b) were recorded simultaneously from adjacent microwire electrodes during mastication using unipolar ground referencing. Signal artifacts are common to both traces. In (c), a bipolar recording between the electrodes of (a) and (b) attenuates mastication noise.

Reproducing our design requires no special in-house facilities; all circuit components are available off-the-shelf and are hand solderable, and the printed circuit board construction may be outsourced.

5.1. Design considerations

The small amplitude extracellular signals typically encountered in neural recordings necessitate a low-noise approach. Since noise performance is always limited by the first stage, the preamplifier is designed to be the quietest and highest gain stage. Preamplifier noise is limited by combining a low-noise, high power op-amp and a low-pass filter. The non-inverting architecture prevents loading of the high-pass filter. While lower noise amplifiers are available, they generally require more power; our preamplifier design is a trade-off between power consumption and noise.

The differential stage is placed immediately after the preamplifier to (1) apply more gain in an early stage and (2) improve signal quality by allowing for the rejection of common mode background signals. We have shown that reference selection can be instrumental in attenuating common mode signal artifacts such as those generated by motion or chewing. The active filter in the differential amplifier's feedback pathway improves the common mode range by adding a high-pass pole to attenuate low frequency offset voltages.

To minimize waveform distortion, the AFE is designed with Bessel filters. This preserves the fidelity of the signals, a necessity if any waveform-based spike sorter is used. Since Bessel filters minimize phase distortion at the expense of sharp filter roll-offs, higher order filters are used. The system has a total of four high-pass and five low-pass poles. The measured phase response of our AFE is approximately linear ($r^2 = 0.98$) making the group delay ($-d\phi/df$) nearly constant in the passband. The maximum group delay at any frequency is ~ 2 ms.

The variable gain stage is placed after the three Sallen-Key filters in order to drive the capacitive input load of the 16:1 time-division multiplexer. The system's overall resolution varies from 18.6 nV/bit at maximum gain and resolution to 4.9 μ V/bit at minimum gain and resolution.

Although we use a precision differential amplifier with a CMRR of 110 dB, we were unable, in practice, to measure CMRRs greater than ~ 42 dB. This can be accounted for by the device tolerances in the preamplifier stage; using $\pm 0.1\%$ resistors and $\pm 5\%$ capacitors in the preamplifier, the expected worst case CMRR at 1 kHz is 39.2 dB. The 8:1 multiplexers providing the reference signals for the differential amplifiers were found to have a negligible effect on the CMRR, even when a single multiplexer was driving all 16 reference lines. To verify our calculations, the preamplifier was rebuilt using $\pm 1\%$ resistors and $\pm 10\%$ capacitors. In this case, we measured the CMRR to be 33.3 dB at

1 kHz, which agrees with the predicted worst case CMRR of 25.4 dB.

In order to facilitate a portable, battery powered product, an emphasis was placed on minimizing power consumption. Low power op-amps with shutdown capability were used where possible. The predicted power consumption for each active channel is 7.3 mW. The analog to digital converter (AD7495) and AC ground buffer (OP262), which are always on, consume a combined 10.2 mW. The two low dropout voltage regulators together only use 0.38 mW.

5.1.1. Noise

The predicted input referred noise for the preamplifier stage is $0.7\mu\text{V}_{\text{RMS}}$, which includes the contributions of the opamp (Maxim 4253) and the passive feedback components. The prediction increases by less than 0.5% when the contribution of differential amplifier stage is added. The actual measured input referred noise ($1.0\mu\text{V}_{\text{RMS}}$) reflects a sum of the circuit noise and the ambient electromagnetic noise. This increase over the predicted noise value was measured in spite of the grounded metal shields. The noise sources reduce the overall system resolution; although the analog to digital converter produces 12 bit samples, only 10.3 bits are more significant than the noise floor at the minimum gain and 6.3 bits at the maximum gain.

6. Conclusion

This work has presented the design and test results of a low power analog front end board for multichannel neural signal processing. This board was designed as part of an

ongoing research effort to develop a portable wireless neural signal recording system.

Acknowledgements

The authors gratefully acknowledge the contributions of Roy Crist, Donald Katz, David Krupa, Aaron Sandler, Jose Carmena, Deborah Won, and Ty Cashen at Duke University, and Harvey Wiggins at Plexon, Inc. This work was sponsored by DARPA Contract No. N66001-02-C-8022.

References

- Hampson RE, Simeral JD, Deadwyler SA. Distribution of spatial and nonspatial information in dorsal hippocampus. *Nature* 1999;402:610–4.
- Katz DB, Simon SA, Nicolelis MAL. Taste-specific neuronal ensembles in the gustatory cortex of awake rats. *J Neurosci* 2002;22(5):1850–7.
- Nicolelis MAL, Ghazanfar AA, Faggin BM, Votaw S, Oliveira LM. Reconstructing the engram: simultaneous, multisite, many single neuron recordings. *Neuron* 1997;18(4):529–37.
- Obeid I, Morizio JC, Moxon KA, Nicolelis MAL, Wolf PD. Two multichannel integrated circuits for neural recording and signal processing. *IEEE Trans Biomed Eng* 2003;50(2):255–8.
- Obeid I, Nicolelis MAL, Wolf PD. A multichannel telemetry system for single unit neural recordings. *J Neurosci Methods* 2004;133:33–8.
- Ohl FW, Scheich H, Freeman WJ. Change in pattern of ongoing cortical activity with auditory category learning. *Nature* 2001;412:733–6.
- Wessberg J, Stambaugh CR, Kralik JD, Beck PD, Laubach M, Chapin JK, Kim J, Biggs SJ, Srinivasan MA, Nicolelis MA. Real-time prediction of hand trajectory by ensembles of cortical neurons in primates. *Nature* 2000;408(6810):361–5.